

# Stop-Loc™

Pat. Pend.

Front Collet Stop Tool Directions

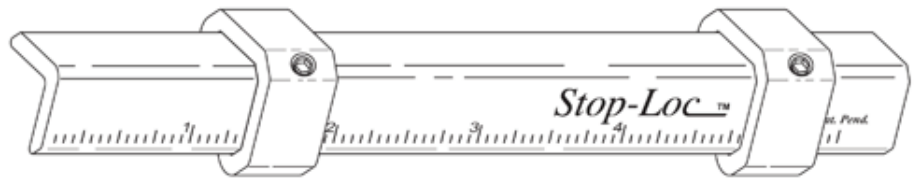

**STEP 1:** Gewünschte Anschlagtiefe mit Hilfe eines Messschiebers (Tiefenmaß) einstellen und mit der kleinen Madenschraube fixieren.

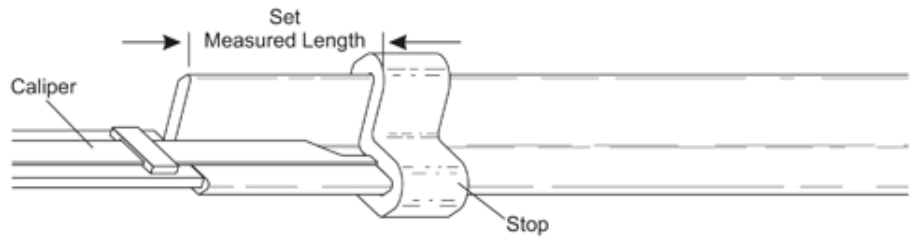

**STEP 2:** Spannzange lösen und Material grob vorziehen.

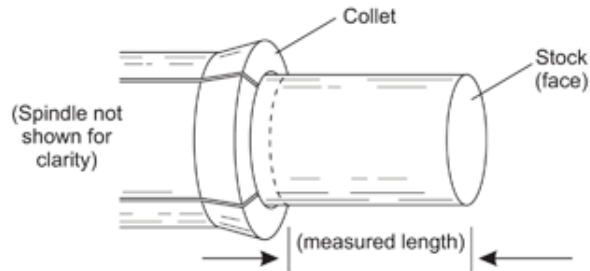

**STEP 3:** Stop-Loc Anschlag anlegen und das Material mit dem Anschlag zurückschieben.

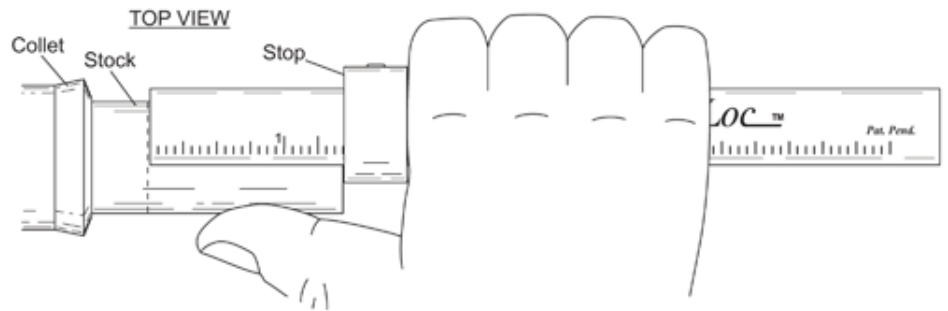

**STEP 4:** Stop-Loc Anschlag gegen Spannzange schieben und Spannzange festsetzen.

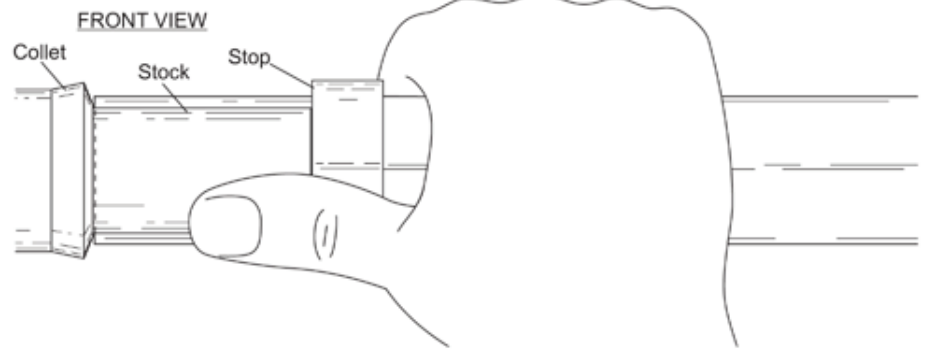

Sample of uses:

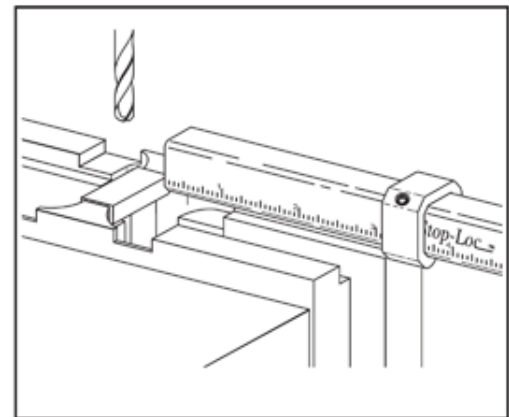
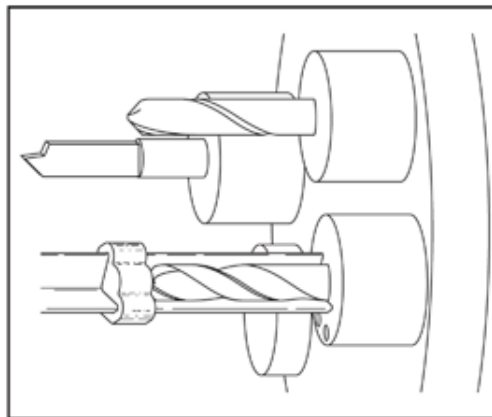
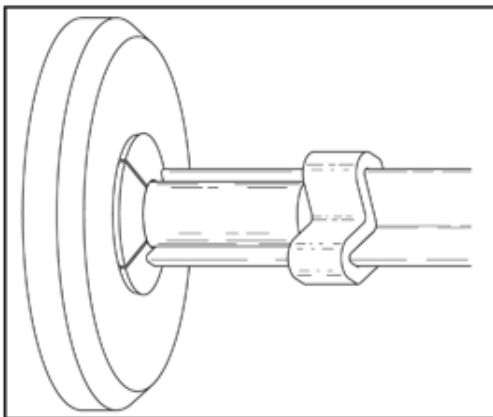

WTN Werkzeug-Technik-Nord GmbH  
Emmy-Noether-Strasse 1  
24558 Henstedt-Ulzburg  
Germany

Tel.: 04193 889178-0  
Fax: 04193 889178-88  
wtn@wtn-gmbh.de  
www.wtn-gmbh.de

